

# DingTec® Laminators

**BU-360 to BU-2040      BU-380II to BU-2040II**

## User's Manual

Version 1.0

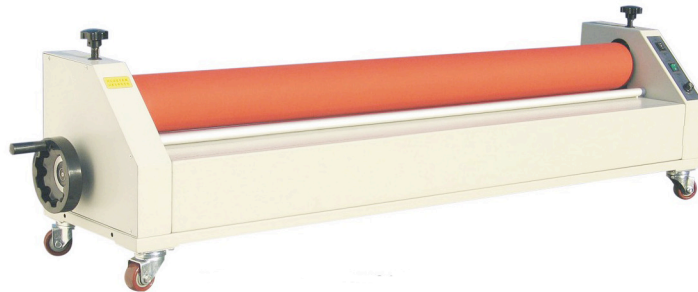
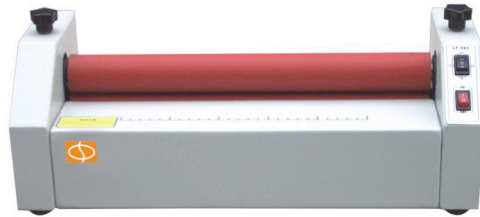

Eastsign International Ltd  
Rm 1406, 14/F., Shatin Galleria  
18-24 Shan Mei Street, Fotan, Shatin, N.T.  
Hong Kong  
<http://www.eastsign.com>

## **PREFACE**

DingTec® BU-360 to 2040 series laminators are low-cost, cold laminators with either manual or automatic operating mode. They are easy to use and install. Users must read this manual thoroughly in order to maximize the capacity of the laminators and avoid damage.

## **I. Main specifications**

### **1. Manual Cold Laminator Series**

Model	Laminating Width (mm)	Laminating Thickness (mm)	Roller's Diameter (mm)	Machine Weight (kg)	Remarks
BU-360	360	5	36	8.5	
BU-450	450	10	50	15.5	
BU-650	650	10	65	24	
BU-1000	1000	15	90	65	
BU-1300	1300	15	90	76	
BU-1600B	1600	23	130	150	With a stand
BU-1600C	1600	23	130	163	With a stand, a foot-wheel, and a plate for pressing picture
BU-1700	1700	25	155	175	
BU-1920	1900	20	155	195	
BU-2040	2000	25	155	200	

### **2. Automatic Cold Laminator Series**

Model	Laminating Width (mm)	Laminating Thickness (mm)	Roller's Diameter (mm)	Machine Weight (kg)	Motor Power	Remarks
BU-380II	380	5	36	8.5	AC 14W	
BU-650II	650	10	65	24	DC 12V 30W	Electric, with foot-pedal, hi/low speed; 650IIZ with a stand for supporting film
BU-650IIZ	650	10	65	24	DC 12V 30W	
BU-1000II	1000	15	90	65	25W	Electric/manual modes, with stand, stepless speed regulating with foot-pedal switch
BU-1300II	1300	15	90	76	25W	
BU-1600BII	1600	23	130	153	40W	Electric/manual modes; with stand; stepless speed regulating; with foot-pedal switch; with foot-wheel, optional plate for pressing picture
BU-1600II	1600	23	102	160	40W	Electric/manual modes; with stand, stepless speed regulating with foot-pedal switch; with foot-wheel; a plate for pressing picture
BU-1600CII	1600	25	130	163	40W	
BU-1700II	1700	25	155	175	60W	
BU-1920II	1900	20	155	195	60W	
BU-2040II	2000	25	155	200	60W	

## II. Manual Cold Laminator

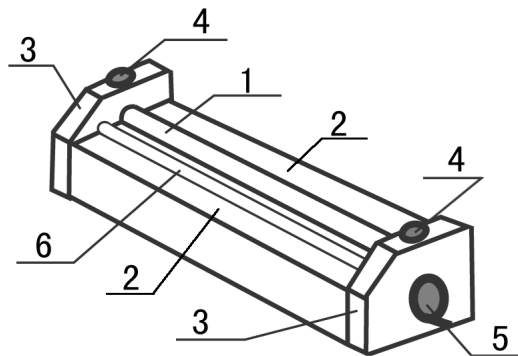

Figure 1

A BU-380 to 2040 series manual cold laminator consists of following parts:

1. The upper and lower rubber rollers
2. The front and back working platforms
3. The left and right supports
4. The knob of adjustment
5. The handle (controlling the rollers)
6. Pressing roller (equipped with BU-1600 models and above)
7. The pedal (equipped with BU-1600 models and above)

While the BU-380 to 2040 series cold laminator have a simple structure and are easy to use, it requires a lot of mounting experiences. Users can gain experience through practice. Appropriate mounting is important to achieve good laminating quality.

The laminating operation typically needs 2 or 3 people working together. The operation varies for different cold laminator models. In addition, electric cold laminator usually needs one person less than its manual counterpart.

There are two basic cold laminating methods, as described below.

### (i) Front Laminating Method

1. Cut one piece of film with the width about the same as that of the picture to be laminated and the length about 5-10 cm longer than that of the picture.
2. Turn adjustable knob counter-clockwise to lift the roller, insert the film into the roller for about 50 cm, then wrap one side of the film around the upper roller. Straighten the film with rollers, align two sides (to ensure the film is straight), then turn the knobs clockwise until idling (Figure 2).

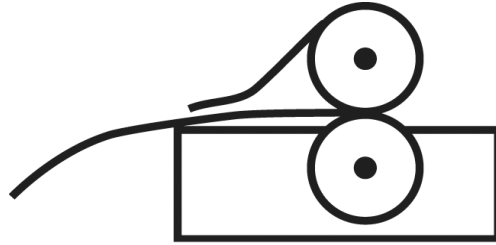

Figure 2

3. Turn the handle and let the film go without picture. Check whether the film is flat. If there are bubbles, it means the pressure is too high, the user needs to raise the rollers to reduce the pressure, then turn the knobs until upper limit of idling or proper position.

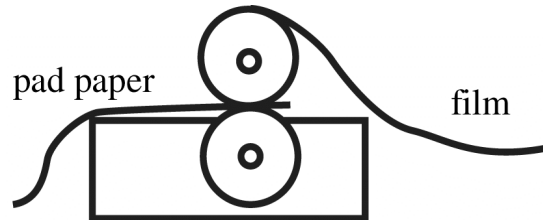

Figure 3

4. Turn the handle counter-clockwise let one side (about 5-10cm) of the film pressed by the rollers. Two persons standing at the each side of the machine work together to tear off the film and stretch the film. At the same time, another person arrange materials in an orderly way where is under roller the film and the padding-paper at separate place. The torn part should be lower than the rollers. It also helps if it is put on clean floor.

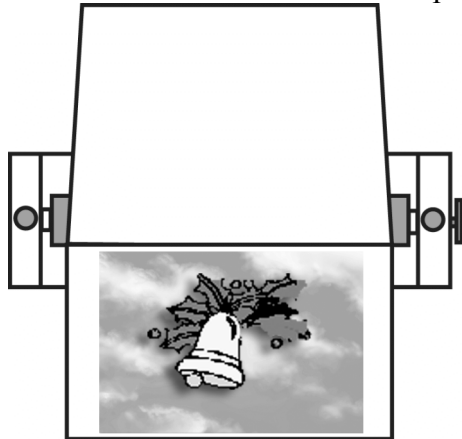

Figure 4

5. Putting the picture on the padding paper, then align the two sides.

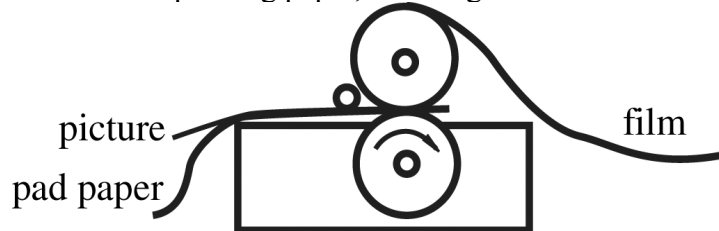

Figure 5

Press the picture under the rollers, align it and flattening and secure the picture with hands. If pressing roller is available, you can use it to pressing the picture on its head. If the picture is thin and long, you can use double-sided adhesive tape to stick the picture on the padding paper (as Figure 4 and 5). Another person should turn the handle clockwise and press the picture into the rollers gradually. If everything goes well, you can speed up to finish the laminating.

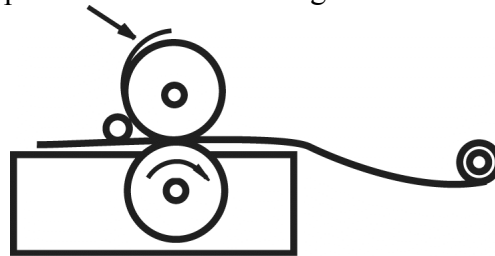

Figure 6

At the end of laminating, you should slow down and keep your hand on the end of the film to avoid any unexpected dropping.

## (ii) Reverse Laminating Method



Figure 7

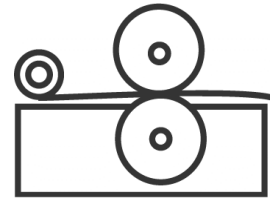

Figure 8

1. Cut one piece of film at about the same size as the picture and make the film face up. Then roll the picture with film and make sure they are well aligned. Put one side of the roll between the two rollers of the cold laminator (make sure it is aligned correctly). The head of the picture should be 30 cm longer than the rollers (Figure 9) put down the rollers and turn the adjustable knob clockwise till idling.
2. Peel one side of the film off the padding paper about 10 cm, fold the padding paper backwards (see Figure 9). After releasing the film, turn the handle counterclockwise, Press the head of the picture and the film, to stick their together and make sure they are still between the rollers. Roll up the film and the picture to let the folded padding paper show up.

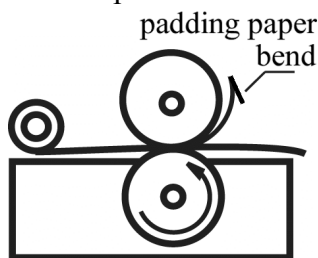

Figure 9

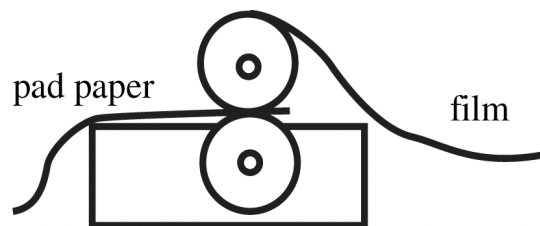

Figure 10

One person should put the film under the roller and let the folded padding paper show up, then secure the padding paper by hands (you can also put the pressing roller on the picture). Another person should turn the handle clockwise at the same time and laminate the film and the picture together. Make sure the film with upper rubber roller should be smooth and the rolled film should be lower than the rollers. While dragging padding paper, the user should drag it at a constant speed and keep pace with the spinning rollers.

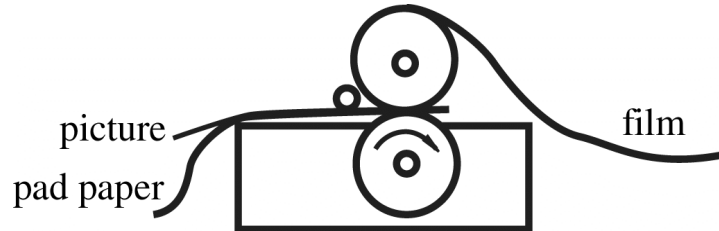

Figure 11

### III. Electric Cold Laminator

The main difference between the manual cold laminator and the electric cold laminator is the electric control part. With the adjustable speed, it is easier to operate and more efficient. The laminating methods are similar to that of the manual cold laminators.

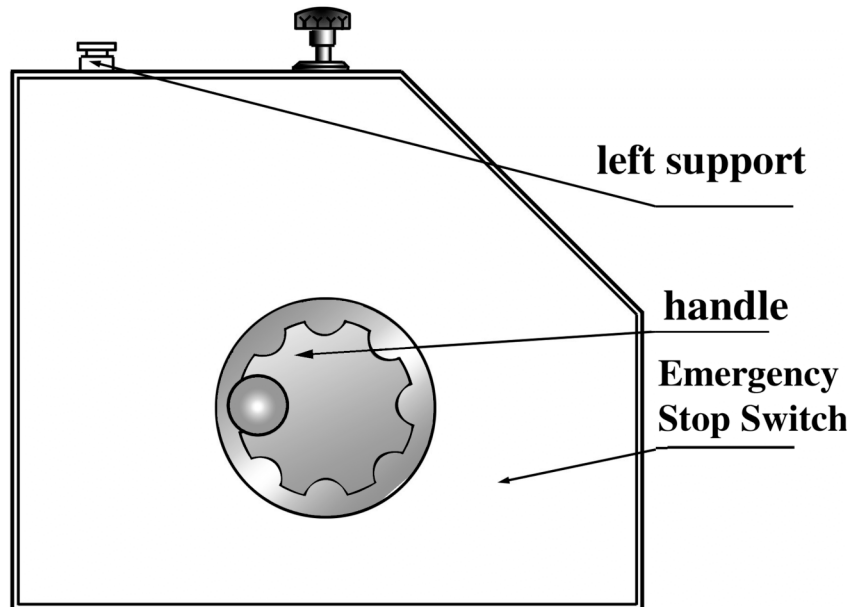

Figure 12

#### Using Electric Cold Laminator

- (1) Connect to power: plug one side of the power cord into the machine and another side to the socket.
- (2) Operation: Select the rotating direction first. Based on the direction, the upper switch is standard rolling, while the lower switch is the reverse rolling. Push upper operational switch to start while push the lower to stop.

If you want to change the spinning direction of the rollers during the operation, you should stop the machine first, then restart to avoid the damages due to suddenly changing directions.

When the operational switch is on the position of the stop, you can use the pedal to operate the machine.

- (3) Speed adjustment: turning the speed adjustment knobs counter-clockwise will reduce the speed; turning the knobs clockwise will increase the speed.
- (4) The sequence to disconnect the power should be done reversibly as the sequence of connecting.
- (5) To ensure a successful process, read the manual carefully before using electric cold laminator.

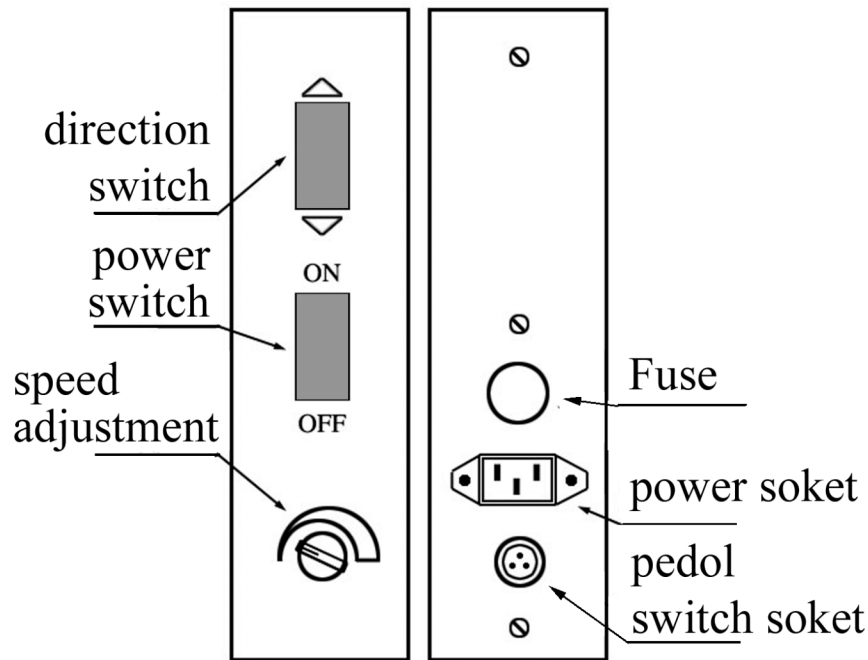

Figure-2

## Using Manual and Electric Transformation Clutch

- (1) There is a set of Jaw Clutch on the left side of the lower rubber roller of the manual/electric cold laminator. Pushing inwards is the electric powered and outwards is the manual operation.
- (2) If you want to use the electric part, you should start running the electric motor slowly. At the same time, push the handle inwards. The clutch might not be geared for a while. Push it further when you'll feel the handle slipping inwards. When the handle and the rubber rollers start rolling synchronously, the electric operation setup is finished. If the handle is not pushed to the right position, the rubber roller will not spin or spin powerless.
- (3) To operate it manually, please pull the handle off while the electric motor is off.
- (4) Attention: while the handle and the rollers rolling simultaneously in electric operation, you should to pull first ten to bend the handle to avoid hurting people. If using electric one in most of the time, you can also take off the handle.

## Notes:

1. When the upper roller is lying over the lower roller by gravity, the knobs can be turned easily at the idling position. Idling position has upper and lower limits. While the knobs is at the idling position, by continuously turn it clockwise, you will reach the lower limit till it is hard to move further; you will reach the upper limit by counter clockwise turning it till it is hard to move further
2. The adjustment knob of BU-360 Cold Laminator is different from that of all other models. To turn it clockwise is to raise the rolle
3. Cold Laminator Supports are optional.
4. Attention in cold laminating operation: While the rollers are tighten together, both pressure adjustment knobs should stay at the idling positions, never raise pressure. When the leading edge of the picture joins the film, make sure it is accurately aligned. If above requirement are not met, it will cause wrinkles and damages to the picture.
5. There are three factors affecting the quality of the lamination: (i) quality of the machine, (ii) the operators' skills and experiences, and (iii) the quality of the film. We advise the users to select the high quality laminators, improve the laminating techniques and selecting high-quality film.
6. When Cold lamination starts, you can slowly spin the rollers, but you cannot stop or reverse it. Otherwise, it will leave an inerasable mark behind.
7. Because of the high static environment while peeling off the film, the working environment should be clean and powerless.
8. To prolong the life of the rollers, you should lift the upper roller after the lamination. You should clean the rubber rollers with high-grade fuel or ethyl alcohol frequently.
9. Avoid the contact with oil, organic agents and scratching. The damages due to the above conditions will not be under warranty.
10. BU-II Cold laminator is an electric one, BU-1000II or above has manual or electric transformation clutch. When using electric cold laminator, you should make sure the voltage on the machine matching the input voltage. Use single-phase 6A3 socket with good grounding.
11. When doing the maintenance, unplug in the machine to avoid electric shock. It should also be disconnected after the work. Before you plug in the machine, check wires and switch of pedal for any damages to avoid accidents.

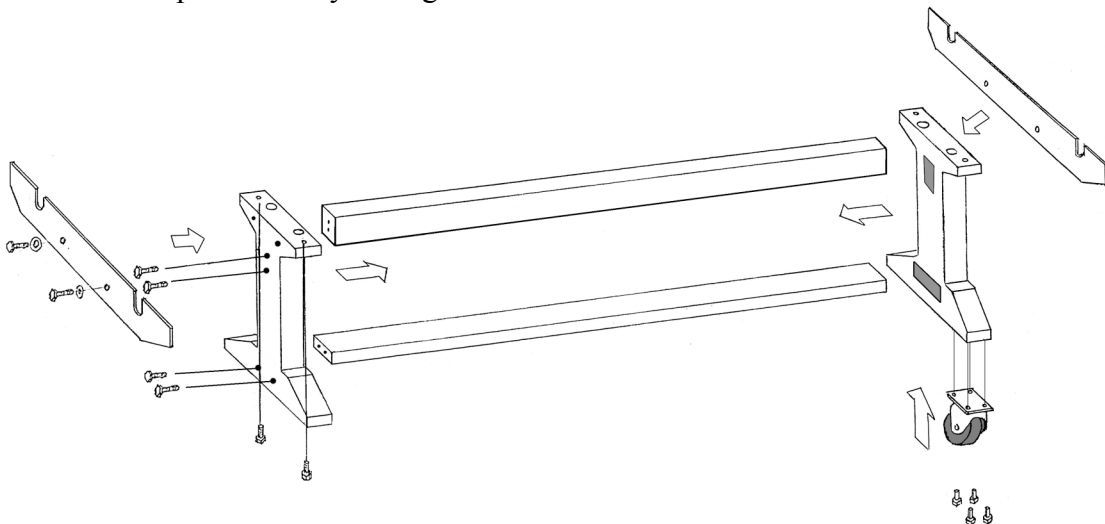

## **Guarantee**

Model		Ex-work serial No.	
User		Purchase Date	
Sales Agent		Phone No.	

### **Notes**

1. The guarantee should be filled in by the sales agent and kept by the user; alterations are prohibited.
2. The guarantee period is 1-year parts, free of charge, and will be charged with material cost hereafter.
3. No free part is available for damages caused by improper use.

Eastsign International Ltd (seal)  
Rm 1406, 14/F., Shatin Galleria  
18-24 Shan Mei Street, Fotan, Shatin, N.T.  
Hong Kong  
Tel: (852) 21170098  
Fax: (852) 21170099  
<http://www.eastsign.com>